

Hampton Wick Association
Consultation on Sainsbury's Local

January 2026

The HWA asked local residents for their feedback – good and bad – regarding the branch of *Sainsbury's Local* which opened on the High Street in February 2025.

We received 27 written responses. (*Verbatim feedback is in italics.*)

1. Positive feedback

- A useful addition to the High Street, allowing local people to access basic groceries on foot, without crossing the river to Kingston or travelling to Teddington
- Polite, friendly, helpful staff
- Useful for picking up Argos purchases

2. Suggestions

- *I was wondering if they would consider installing a cash machine as the one by the Post Office seems to be no longer working and while the PO does allow for withdrawals, it only does so during office hours which are limited.*
- *What would be really useful would be a more reliable supply of green vegetables and a wider variety of fruit. Smaller packets are also particularly useful for single-person households*

3. Concerns to be addressed

Deliveries: timing, obstructing the road and pavement, noise

Shoplifting

Out of hours waste collection: timing, noise, dangerous driving, engines idling (illegal)

Signage / lighting: brightness and angle of light, dangerous/annoying for motorists and pedestrians, hours of operation

Litter

Other: road safety, graffiti, noise, insufficient staffing, smoking/vaping

Deliveries

- Any lorry delivery sounds very similar to scaffolding being erected. I honestly don't think you can unload a tail lift HGV any louder, it's beyond unacceptable whatever time of the day.
- Traffic congestion obstruction from delivery vehicles
- Their delivery vans cause hold ups to buses, police cars, ambulances and the high street traffic in general.
- Deliveries to this store often increase traffic congestion in this narrow part of the High Street. The lorries involved are much wider than the cars which might otherwise be in those parking spaces, and lorries often stop outside these bays. This is a busy bus route, apart from traffic going to/from Kingston.
- Today at around 10.35 High Street effectively reduced to a single lane
- Deliveries to the store have generally been after 08:00 and before 19:00 on weekdays and weekends, including Sundays. A large white lorry is being used.
- In addition to the noise, this has added to significant congestion on the high street and at least a few near miss accidents due to restricted visibility.
- Their deliveries can be very poor. This delivery just stopped in the middle of the road and delivered there which blocked the road. It looked like this was because a Sainsbury delivery van had already parked up outside the store and Hovis didn't want to wait to make their delivery



Note: wrong side of road, completely blocking one carriageway, opposite bus stop so potentially blocking entire road both ways, blocking access for any other vehicles to side road / flats in Jubilee Close (next to white building in photo).

- *I walked along the High Street to the tailor this morning. As I approached the new JS, the pavement (it's quite narrow there) was completely blocked by three or so people managing cages of goods in to the store with empty ones coming out. I had to walk around the large van in the middle of the street. What's more, the lorry was blocking the entrance to Jubilee Close.*



Shoplifting

- *Clearly visible happening on a daily basis in the shop*
- *It's not clear to me whether shoplifters are travelling specifically to Sainsburys to steal or if it is opportunity for thieves who would otherwise be in Hampton Wick anyway, but we are concerned that if this remains unchecked it could escalate to broader criminal activity and potentially extend to other shops on the High Street. It is also extremely frustrating as a paying customer to see people simply walking out of the shop unchallenged having plainly stolen items from the shelves.*
- *I am sure you will be aware that the police have had to deal with youngsters and others attempting to petty thieve*
- *Incidents observed by chance include:*
 - o *groups of younger people loitering on Jubilee Close then wandering in one by one and taking smaller items from the first aisle*
 - o *a couple entering the store and then the man sprinting out of the store with full baskets of product (including wine and a baguette among many other items!). In this instance a member of staff came to the door to see where the man had gone. He was hiding a few doors down in a neighbour's doorway, until the woman emerged with shopping in a carrier bag. They then casually got into their car and drove off.*

Out of hours waste collection

The large waste trucks have arrived, sometimes as early as 05:00 a.m., and sat with their engine running for over 45 mins in some instances. On occasions, the waste truck operator even spends time banging on Sainsbury's door to get attention from the staff.

This has been followed by waste being collected through the front door of Sainsbury's and the waste crushing mechanisms started in the trucks still out of hours. (Anyone who has stood within 5 metres of an operating waste truck will know this is very loud).

Subsequently followed by the vehicle reversing alarm running as the waste truck attempts to reverse into Jubilee Close. (This manoeuvre itself has resulted in a few near misses including nudging the exterior wall of our opposite neighbour's house and garden wall).

We have even contacted the CEO of Sainsbury's directly which did, at least, make a difference for a short period of time and for the short reprieve we are thankful.

The issue persists none-the-less.

Signage / Lighting

- The illuminated signs are really annoying as the lights don't just illuminate the sign but they shine right in your face.
- Over-lit shop facade having impact on nocturnal wildlife
- I notice that the lighting of the projecting sign (i.e. the one that sticks out perpendicular from the store front above the pavement) reflects brightly from a reflective metal part of the support. This means that when you are standing anywhere not directly under the sign you see a bright reflection of the led lighting. This is unsightly and I believe not in keeping with the intention of the approved planning permission. Below is a side on view of the sign from the planning application where I have highlighted the reflective part in question in a red box.

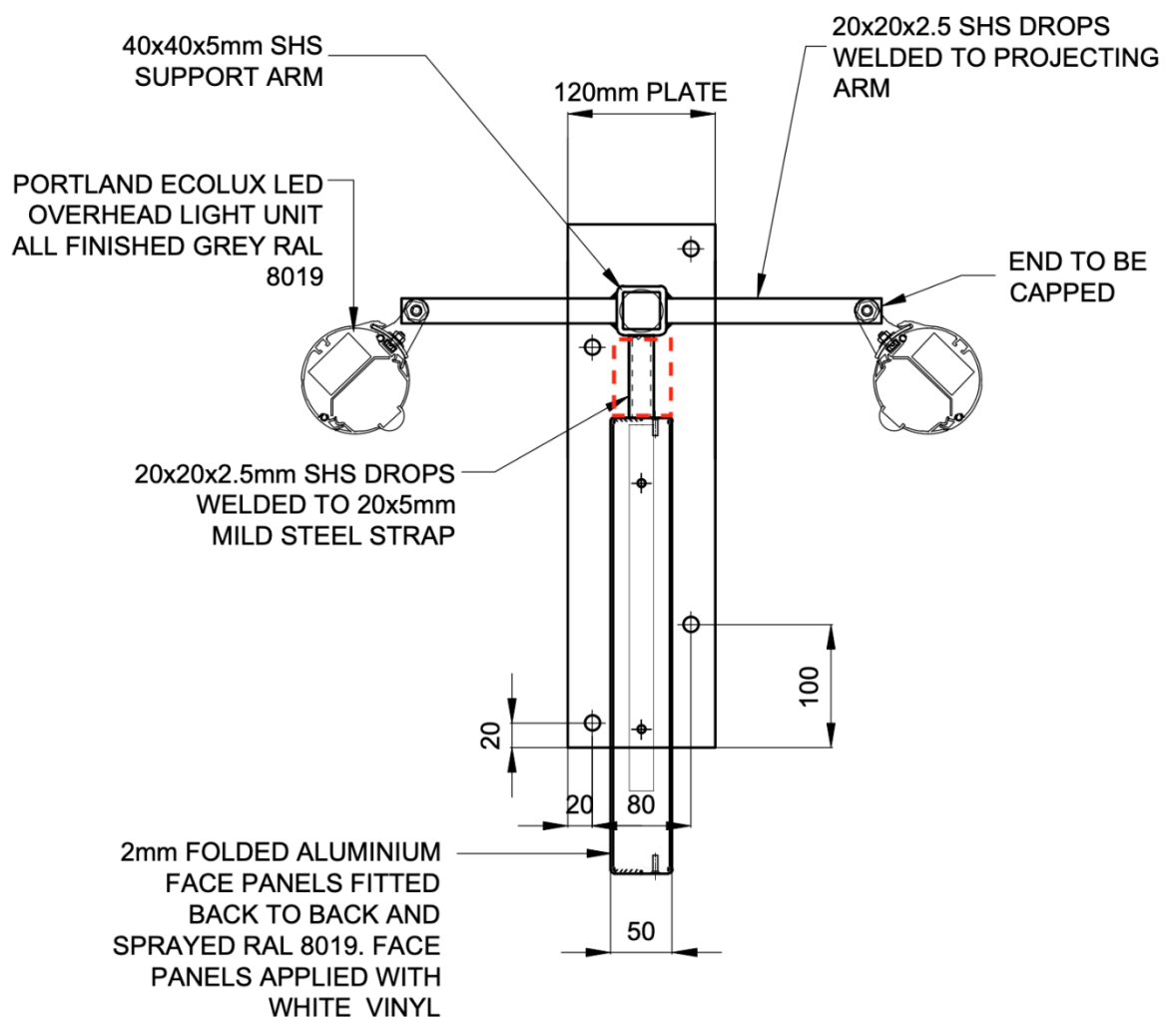

I am not sure of the best solution, but this may include adjusting the angle of the lighting and/or covering the reflective metal in a non-reflective coating.

The lighting on the signs is also an issue for motorists. Additionally, these lights are on all day and all night, extending the period of discomfort for those affected and wasting electricity and damaging the environment.

Litter

- *I have noticed quite a lot of litter along the pavement outside the shop at times, which isn't very nice for the residents close by.*
- *There are no bins between the two bus stops on this side of the street. This seems insufficient now because of an increase of local rubbish and litter since the shop opened*
- *Someone started regularly leaving Sainsbury's bags of rubbish in our bins. We wonder if this could be staff and we would appreciate it if the manager could tell staff to use either use public bins or make proper arrangements for rubbish.*

Noise (fixed equipment)

- *To the rear of Sainsbury's is a large electric extraction device, either linked to heating or refrigeration. It runs at excessively loud noise level 80/90% of their opening hours.*

Road safety

- *One of the knock-on effects of Sainsbury's opening on the High Street is the changing use of the parking bays outside. Previously used by residents, the bays are now also used by people parking up to quickly pop into Sainsbury's. The nature of the store encourages quick visits.*
- *We have organically witnessed a number of near-miss accidents with drivers parking to go into Sainsbury's and quickly opening their car door in the path of a cyclist or other driver. This has caused the cyclist / driver to break hard or swerve to avoid hitting the person getting out of the car, sometimes finding themselves heading into the path of oncoming traffic.*

Graffiti

- *They should remove it ASAP. I reckon I could get it off in five minutes with some spirit, Cif and elbow grease.*

Smoking / vaping on private property

- *Our back gate opens onto School Road next to the garage doors. This is a small piece of private land where we keep our bins and those of number 51. When the Sainsbury's first opened staff frequently loitered there to smoke and vape. I think our neighbour must have complained because that has become less common. But I think the manager needs to think more carefully about where staff smoking or vaping is appropriate.*

Not enough staff

- *It is rare to see a member of staff serving customers at the main counter / till. I almost always have to go and find a staff member and ask them to come and serve me.... Basically, they appear to be running the store with one member of staff less than they should be to run a customer -orientated business.*